

Installing The Metlund® D'MAND® System for S-02

1. Check the package contents

Your **Metlund System** Includes:

S-02 MODEL 0011 PUMP (ONLY)

- A pre-assembled S-02 pump/zone valve assembly
- Set of flanges + gaskets
- A plastic bag with 2 zip-ties, 1 push-button
- A 3/4" threaded reducer to sweat 1/2" pipe

S-02-PF-R MODEL 0011 PUMP (ONLY)

- A pre-assembled S-02 pump/zone valve assembly
- Set of flanges + gaskets
- Set of T's
- Set of Flex-line
- One double threaded elbow
- A plastic bag with 2 zip-ties
- An R0954 remote control package

2. Installing the System

Flange Set-up

Lay pump out with electrical box on top & flange fitting to rear. Open box with flange parts and layout. For each side of the pump's flange fittings, you will need: 2 nuts, 2 bolts, 1 flange plate, 1 gasket & 1-3/4 female ball valve housing (FBVH). Note that on one side of the flange plate is an indentation for the FBVH to set into. Set into position and place gasket over this assembly. Next, set gasket side of assembly against flange fitting on pump and secure with nuts and bolts provided. Leave fairly loose until other parts are added. Repeat to other side of pump. (Note: On the FBVH is a flat head screw adjustment that closes off the water supply by adjusting the screw perpendicular which closes the ball valve should pump replacement be necessary. This adjustment set in the horizontal position would be full open.)

Attaching Zone Valve & 3/4 Male Elbow

The zone valve has two male fittings attached. The straight piece is on the incoming side of the valve and the elbow on the outgoing side. Place Teflon tape on the incoming thread and screw on outgoing side of pump onto FBVH. (Left side as pictured or see arrow on bottom of pump) Next, place Teflon tape onto the male fitting on the shorter side of elbow. Screw this into place on the FBVH attached to the incoming side of pump. Both of the male fittings should be pointing upward, then nuts & bolts of the flange assembly should be tightened in place.

LOOKING DOWN ONTO PUMP

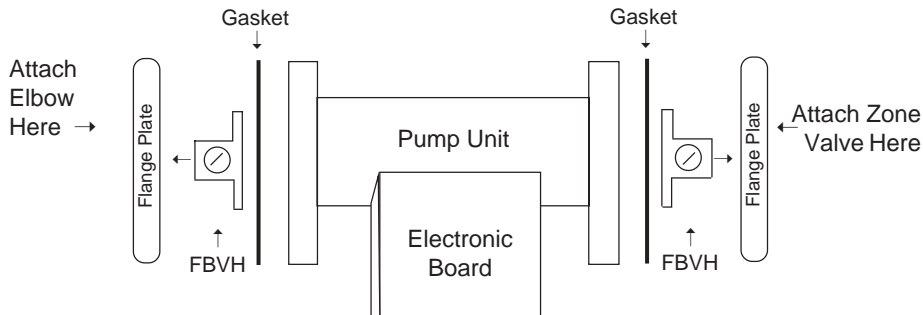

METLUND® LIMITED WARRANTY

ACT, Inc. Metlund® Systems will replace without charge (at the company's option) any Metlund® D'MAND® pump, valve, or component part which is proven defective under normal use. Model S-01 Series and Model S-02 Series: Warranty-five years from date of purchase; Model S-46 Hot Shot Series: Warranty-three years from date of purchase; Model P-01 Series and Model P-02 Series: Warranty three years from date of purchase. Accessories: Hard-Wired Buttons and Remote Activators and Receivers: Warranty-one year from date of purchase. Labor is not included with Metlund® Limited Warranty.

In order to obtain services under this warranty, it is the responsibility of the purchaser to promptly notify the Company in writing and promptly deliver the item in question, delivery prepaid to the factory. The address for notification and delivery is ACT, Inc. Metlund Systems, 3176 Pullman Street, Suite 119, Costa Mesa, CA 92626. If the product or part in question contains no defect as covered in this warranty, the purchaser will be billed for parts and labor charges in effect at the time of factory examination and repair.

Any Metlund product or part not installed or operated in conformity with Metlund instructions or which has been subject to misuse, misapplication, the addition of petroleum based fluids or certain chemical additives to the system, or other abuse, will not be covered by this warranty.

ACT, Inc. Metlund Systems OFFERS THIS WARRANTY IN LIEU OF ALL OTHER EXPRESS WARRANTIES. ANY WARRANTY IMPLIED BY LAW INCLUDING WARRANTIES OF MERCHANTABILITY OR FITNESS IS IN EFFECT ONLY FOR THE DURATION OF THE EXPRESS WARRANTY SET FORTH IN THE PARAGRAPH ENTITLED "LIMITED WARRANTY" AS SHOWN ABOVE.

THE ABOVE WARRANTIES ARE IN LIEU OF ALL OTHER WARRANTIES, EXPRESS OR STATUTORY, OR ANY OTHER WARRANTY OBLIGATION ON THE PART OF ACT, INC. METLUND SYSTEMS.

ACT, INC. METLUND SYSTEMS WILL NOT BE LIABLE FOR ANY SPECIAL, INCIDENTAL, INDIRECT OR CONSEQUENTIAL DAMAGES RESULTING FROM THE USE OF ITS PRODUCTS OR ANY INCIDENTAL COSTS OF REMOVING OR REPLACING DEFECTIVE PRODUCTS.

This warranty gives you specific rights, and you may have other rights which vary from state to state. Some states do not allow limitations on how long an implied warranty lasts or on the exclusion of incidental or consequential damages, so those limitations or exclusions may not apply to you.

TROUBLESHOOTING Diagnosing Specific Problems

Problem	Possible Cause	Remedy
1. The pump does not run when push button is pressed	A. No power at electrical outlet B. You've plugged the controller into an electrical outlet controlled by a wall switch, (such as the outlet under many kitchen sinks that controls the garbage disposal.) C. Power cord is not secured to pump and valve D. Wire to push button is not connected well E. The temperature setting is already sensing "hot" water so the pump is not being activated	<ul style="list-style-type: none"> • Plug the controller into a "hot" outlet • Shut off power, then make sure wires have good contact • Reset the water temperature setting on the controller to be less sensitive (see page 3)
2. The water is not hot enough	A. Pump or valve was installed with water flow going in the wrong direction B. There is something in the piping that has blocked the flow of water	<ul style="list-style-type: none"> • Check the arrows on the housings of the valve and pump to make sure they point in the correct direction (see page 2) • Check the piping for obstruction
3. There is hot water at the cold water tap	A. The water temperature sensor is positioned incorrectly B. The temperature sensitivity setting now in place is too low, so the pump is not shutting down soon enough	<ul style="list-style-type: none"> • Check the position of the water temperature sensor to make sure it is firmly attached to the pipe • Carefully turn the pot hole adjustment 1/8 turn at a time clockwise (small standard screwdriver)
4. Water is not hot enough when pump shuts down	A. The temperature sensitivity setting now in place is too low, and the pump is turning itself off too soon	<ul style="list-style-type: none"> • Carefully turn the pot hole adjustment 1/8 turn at a time counter clockwise (small standard screwdriver)
5. There is hot water in the cold water lines only	A. The pump is installed backwards	<ul style="list-style-type: none"> • Reinstall the pump correctly



ACT, Inc. Metlund® Systems
3176 Pullman Street, Suite 119, Costa Mesa, CA 92626
1-800-638-5863 • info@metlund.com

METLUND®

(S-46, S01, and S02) PreFab Systems

S-Series Hot Water D'MAND® Systems
For Standard Piping (non-recirc)

Installation and Operating Instructions

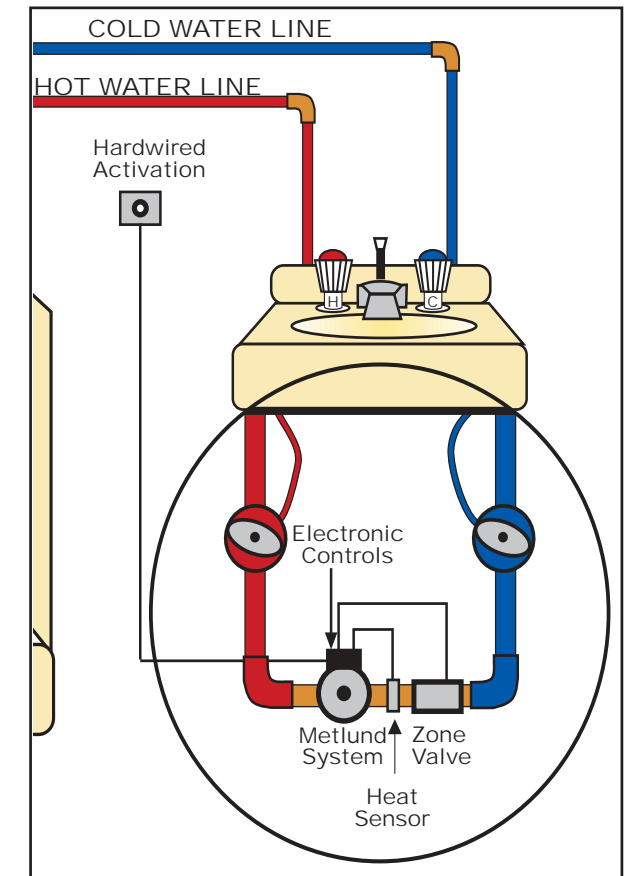

*S-46 models do not have zone valve shown above

Please leave these instructions with the owner for future reference

“Installations shall be in accordance with the manufacturer’s instructions per the requirements of the Uniform Plumbing Code (UPC)”

Be Careful

Do not plug the power cord into an electrical receptacle until system is installed and in place. Operation of the system without being plumbed into the water lines will burn out the pump prematurely and **void the warranty**.

Pre-Installation Checklist

1. Check the package contents

Your **Metlund System** Includes:

- A pre-assembled Metlund Controller/Circulator Pump/Zone Valve Assembly
- S-46 models will not show zone valve. Zone Valve is inside the pump housing.
- Compression fit copper T’s (S-01PFR). (Homes with galvanized pipes will need galvanized T’s).
- A plastic bag containing: one (1) push-button
- (If wireless remote option was purchased) one transmitter, one receiver, one 12V battery, three gray wire nuts & three screws.

Check the components for visible damage and contact your supplier immediately if any damage is found.

2. Make sure you have the tools to do the job

No special tools are required to install the **Metlund System** other than those tools usually needed in any plumbing job. They include:

- Pipe wrench or crescent wrench
- Pliers
- Small Phillips head and medium flat head screwdriver
- Wire strippers
- Drill and 5/8" drill bit
- Soldering equipment (if applicable)

3. Determine where you will install The System

Typically, this should be at the fixture farthest away from the water heater. If your hot water supply line runs in two separate directions from the water heater, you may need more than one **Metlund System** to satisfy all of your hot water requirements.

Installing The Metlund® D'MAND® System for all S-Series Systems

This is for installation of the PF Accessory T's only. These do not replace the existing instructions included with your system. Be sure you have read the instructions carefully before proceeding with your installation.

You have purchased a Metlund Hot Water Demand System that is equipped with the PF accessory package. The 1/2" male thread adapters have already been pre-sweat to your Metlund System.

Enclosed with your system, are two T's designed to simplify your installation to 1/2" copper hot and cold supplies.*

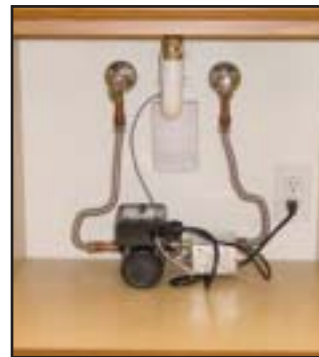

Installation must be as shown above

To Install Your “T” Fittings

1. Turn off the house water supply.
2. Open the hot and cold faucets at the fixture chosen for installation. This will relieve the water pressure from the hot and cold water pipes.
3. Remove the shut-off valves that supply hot and cold water to the sink from the 1/2" copper pipe. For ease of installation, leave the compression ring and nut from the angle stop on the hot and cold water supplies.
4. Remove the compression ring and nut from the enclosed compression fitting on the PF-T's, and slide onto the other end. Attach the existing nut and ring to the end of the threaded T and firmly tighten.
5. Install the remaining compression ring and nut to the shut-off valve, slide onto the 1/2" side of the PF-T and firmly tighten.
6. Now you are ready to attach flex lines from the 1/2" male thread of the PF-T's to your **Metlund D'MAND System**. (Teflon tape is recommended for the 1/2" threaded fittings.)
7. Refer to Page 3 - “Installing the Demand Button(s)” and “Wireless Remote Option”.

** Additional fittings may be required if your supply lines are galvanized or plastic pipe.*

METLUND “NO SWEAT” SYSTEM ADAPTS TO YOUR EXISTING PLUMBING! FOLLOW THESE SIMPLE STEPS:

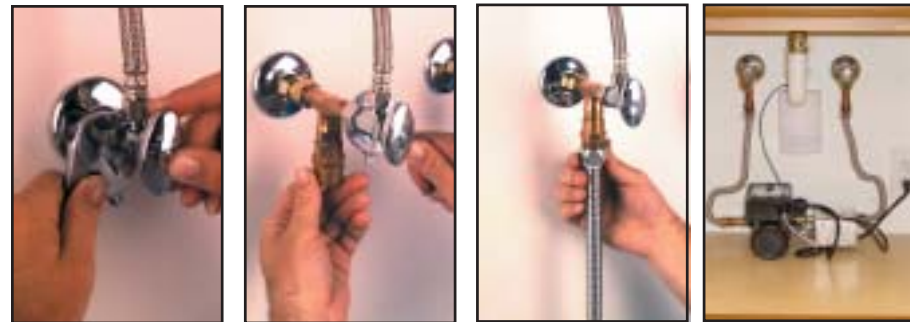

1. Turn off water supply and remove angle stops.

2. Install & tighten T's (included), attach angle stops.

3. Install copper flex lines or any line with 1/2" inside diameter.

4. Connect Metlund System, install push button and plug in.

Installing The Metlund® D'MAND® System for all S-Series Systems

1. Installation Procedures

- A. Turn off the house water supply.
- B. Open the hot and cold faucets at the fixture chosen for installation. This will relieve the water pressure from the hot and cold water pipes.
- C. Remove the shut-off valves that supply the hot and cold water to the sink.
- D. Install T-fittings to the pipe stubs from the hot and cold water supply.

1. Installation Procedures (continued)

NOTE: Using piping with less than 1/2" inside diameter will restrict the flow of the water, causing it to take longer for hot water to arrive. Before sweating 1/2" pipe to zone valve, be sure zone valve is in manual position.

- E. Install the **Metlund System** between the hot and cold lines, but be sure that the arrows on the pump and the valve point from the hot side to cold as shown in **Figure 1**.
- F. Re-install the shut-off valves to the water supply and sink.

This is the recommended position for installing the **Metlund System** with the flow of the hot water into the pump side of the system and the valve side into the cold water line. The pump should lay on its side with the controller on top. (Figure 1)



Figure 1

2. After installation adjustments

CHECK THE SYSTEM CAREFULLY TO MAKE SURE THE INSTALLATION IS FREE OF WATER LEAKS.

All Electronic Sensitivity Adjustments are pre-set at the factory. **If adjustments are necessary please call 1-800-638-5863 for technical help prior to making any adjustments.** However, please make sure the off sensor (green tip wire), is firmly attached and is touching the pipe. The sensor is designed to signal the controller to shut off automatically when **hot water** has reached your fixture, and not to reactivate if **hot water** is at the fixture. Review the troubleshooting page for additional information.

3. Try the Metlund® System and check water temperature

Once installed, turn water supply on and plug in the system. (Pump will automatically turn itself on when it is initially plugged in without pushing the demand button). The Metlund System will continue to operate until the sensor signals that hot water has arrived, then it will automatically shut off. To test the system again, wait until pipes cool down. You may then test the system by pushing the demand button, or to pre-test your system after plugging the unit into 110v outlet, place a hot rag over thermosensor located to the right of the ump housing. The unit will shut off immediately. Remove rag from sensor and test remote switches.

To operate the Metlund System from another location in the home, place remote button in desired location. Push remote button (red activation light will light up when pushed), wait a few seconds for system to cycle. You may now turn on hot water. **NOTE: The Metlund Controller is designed with an automatic safety feature that will shut off the pump in approximately three minutes.**

4. Installing the Demand Button(s)

To install the Demand Button, follow these steps:

- A. Drill a 5/8" hole into the desired location.
- B. Insert the 5 foot gray wire from the controller through the back side of the hole and connect it to the push button switch. Then, firmly insert the push button back into the hole. Additional push button switches can be spliced into the same wires. It is important to use a button comparable in quality to the button provided.

Wireless Remote Option - R0954

Wiring The Receiver

The remote receiver is the white rectangular box with the three protruding wires: black, white & green. **This does not need batteries.** Wire the receiver directly to the corresponding wires on the controller by twisting each same colored wire together with gray wirenuts provided. Receiver should be mounted toward front of cabinet. (Range of transmitter is about 70'). If transmitter will activate system from short distance, but not from further away, receiver may need to be relocated for better reception. Strapping receiver to front of drain trap facing outward will optimize reception.

Installing Batteries to the Transmitter

Open transmitter with a small flat head screwdriver by inserting screwdriver into slot to release catch. Load battery with negative side of battery toward spring. Carefully replace cover. When button is depressed, red indicator light should turn on. Numbered jumper pins are inside the transmitter and receiver. The signal frequency can be changed by removing the same numbered pins from both the receiver and transmitter. **This should only be necessary when two D'MAND® Systems are in same home or your neighbor has the system.**